

Bulletin 20-4-7
Wiring methods for diesel fuel dispensers located in hazardous areas
Rules 20-002 and 20-004

Issued May 2023
Supersedes Bulletin 20-4-6

Background

Electrical Inspectors are often asked what wiring methods are acceptable for diesel fuel dispensers. Although diesel fuel does not constitute a hazard similar to gasoline, diesel dispensers are often installed in proximity to gasoline dispensers. This *may* have a direct impact on the acceptable wiring method to supply the diesel fuel pump.

Direction

Diagram B1 shows typical installation of a diesel fuel dispenser installed in proximity to a gasoline fuel dispenser.

Diagram B2 *shows the hazardous classification for gasoline tank fill/vent cap*

Diagram B1 – Diesel fuel dispenser installed in proximity to gasoline fuel dispenser

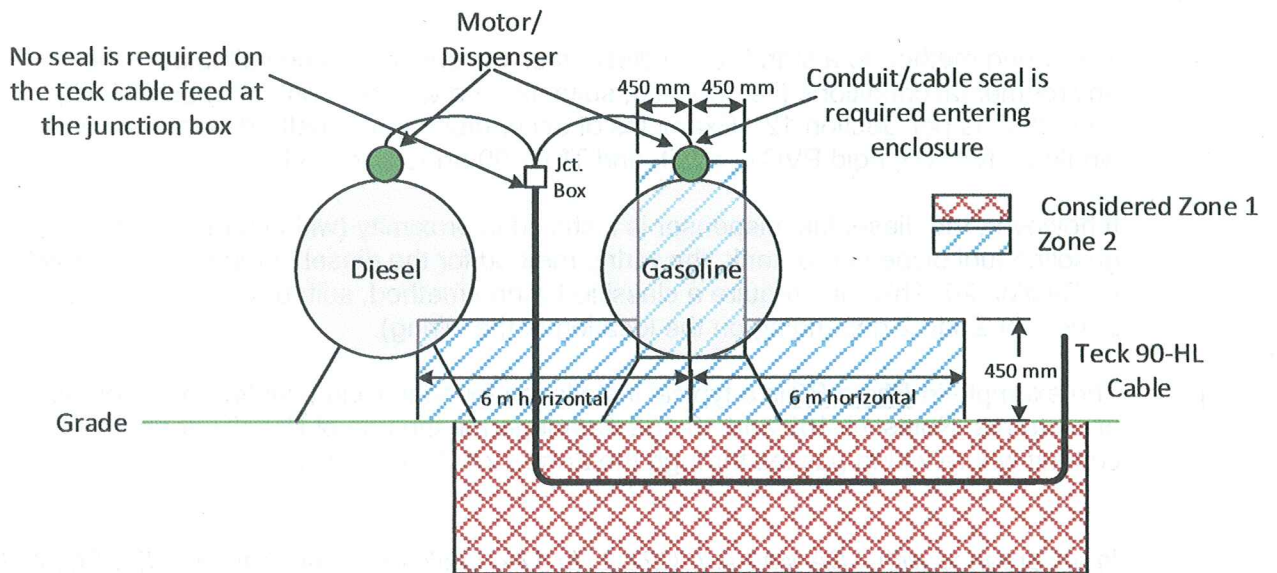
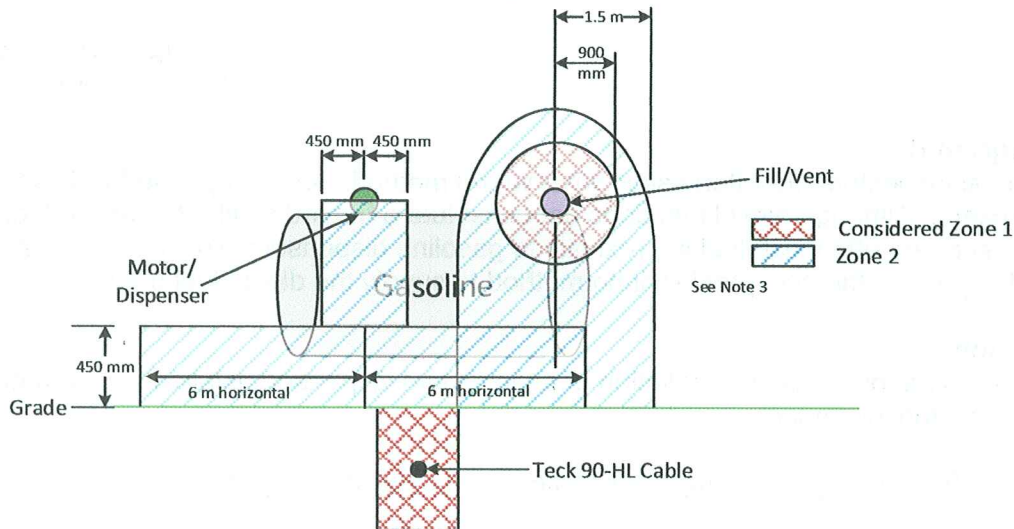

Diagram B2 – Hazardous classification for gasoline tank fill/cap



Fill/Vent

- 1) Spherical volume 900 mm radius from fill/vent – Zone 1
- 2) Between 900 mm and 1.5 m radius from fill/vent – Zone 2
- 3) if venting discharges downwards, area extending to the ground shall be Zone 2 as per Rule 20-004 9)b)

The wiring method to a stand-alone diesel fuel dispenser shall be suitable for the environmental conditions (i.e.: outside, suitable for a wet location and mechanically protected as per Section 12). Examples of acceptable wiring methods that may be used would be NMWU, rigid PVC conduit, and TECK90 armoured cable.

If however, the diesel fuel dispenser is installed in proximity (within 6 meters) to a gasoline fuel dispenser or tank, the wiring method for the diesel pump may be impacted by Section 20. This may require a classified wiring method, suitable for the area (either Zone 1 or Zone 2 depending on the location of the wiring).

The example in *Photo B2* is a typical installation found in road maintenance work yards or on farms. Rules 18-102 and 18-152 do not permit the use of NMWU or rigid PVC conduit where wiring passes through the Zone 1 or Zone 2 locations.

In accordance with CSA standard C22.2 No.174, cables shall be marked "HL". Photo B1 shows an example of TECK 90-HL marking.

Photo B1-TECK90 non-metallic outer jacket marking

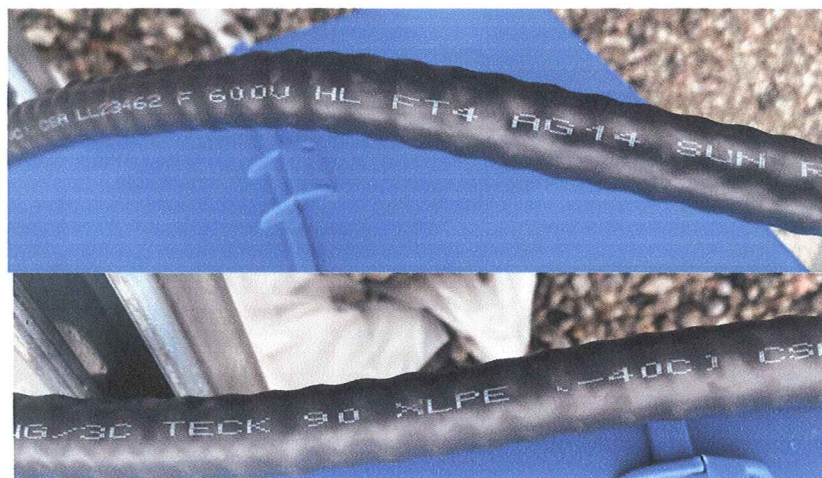

As per Diagram B1, if the TECK90-HL armoured cable is unbroken and passes completely through the classified areas, then seals shall not be required at either end of the TECK90-HL cable when terminating in a non-hazardous area. The electrical supply to the gasoline pump motor from the junction box shall require a seal at the motor.

Additional precautions shall be made for buildings located within the 6 meter radial dimension around gasoline dispensers. If the building is not suitably cut-off by a wall or other acceptable means, the hazardous area extends into the building, as noted in Rule 20-004 6).

Photo B2 – Typical installation of diesel fuel dispenser installed in proximity to gasoline fuel dispenser

